

User's guide

SMA2 + MTA2

Absolute linear encoder

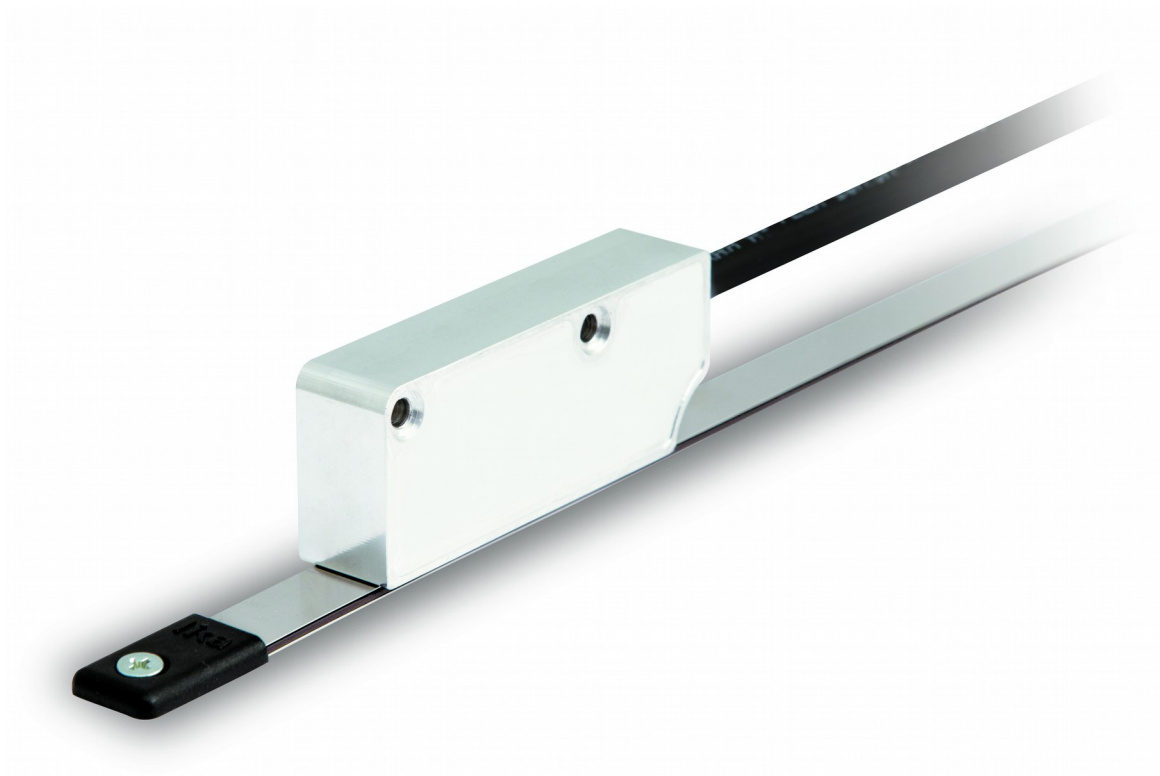

lika

Smart encoders & actuators

This publication was produced by Lika Electronic s.r.l. 2016. All rights reserved. Tutti i diritti riservati. Alle Rechte vorbehalten. Todos los derechos reservados. Tous droits réservés.

This document and information contained herein are the property of Lika Electronic s.r.l. and shall not be reproduced in whole or in part without prior written approval of Lika Electronic s.r.l. Translation, reproduction and total or partial modification (photostat copies, film and microfilm included and any other means) are forbidden without written authorisation of Lika Electronic s.r.l.

The information herein is subject to change without notice and should not be construed as a commitment by Lika Electronic s.r.l. Lika Electronic s.r.l. reserves the right to make all modifications at any moments and without forewarning.

This manual is periodically reviewed and revised. As required we suggest checking if a new or updated edition of this document is available at Lika Electronic s.r.l.'s website. Lika Electronic s.r.l. assumes no responsibility for any errors or omissions in this document. Critical evaluation of this manual by the user is welcomed. Your comments assist us in preparation of future documentation, in order to make it as clear and complete as possible. Please send an e-mail to the following address info@lika.it for submitting your comments, suggestions and criticisms.

The logo for Lika Electronic s.r.l. consists of the word "lika" in a bold, lowercase, sans-serif font. The letter "i" has a dot, and the letter "a" has a tail that curves slightly to the right. The logo is positioned in the bottom right corner of the page.

General contents

User's guide.....	1
General contents.....	3
Subject index.....	5
Typographic and iconographic conventions.....	6
Preliminary information.....	7
1 - Safety summary.....	8
1.1 Safety.....	8
1.2 Electrical safety.....	8
1.3 Mechanical safety.....	9
2 - Identification.....	9
3 - Mounting instructions.....	10
3.1 Overall dimensions.....	10
3.2 Magnetic scale.....	10
3.3 Mounting the sensor.....	11
4 - Electrical connections.....	13
4.1 M12 8-pin connector specifications.....	13
4.2 M8 cable specifications.....	13
4.3 Ground connection.....	14
4.4 AB incremental output signals.....	14
4.5 Features summary.....	14
5 - SSI interface.....	15
5.1 SSI (Synchronous Serial Interface).....	15
5.2 "MSB left aligned" protocol.....	16
5.3 Recommended transmission rates.....	18
5.4 Error bit.....	18
5.5 Helpful information.....	19
5.6 Recommended SSI input circuit.....	19
6 - BiSS C-mode interface.....	20
6.1 XML file.....	20
6.2 Communication.....	20
6.3 Single Cycle Data.....	21
Position.....	21
Error.....	21
Warning.....	22
CRC.....	22
6.4 Control Data CD.....	22
Register address.....	22
RW.....	23
DATA.....	23
CRC.....	23
6.5 Used registers.....	24
Profile ID.....	24
Serial number.....	25
Command.....	25
Normal operation.....	25
Save parameters on EEPROM.....	25

Save and activate Preset / Offset.....	25
Load and save default parameters.....	25
Configuration	26
Set preset / offset.....	26
Enable preset / offset.....	26
Output code.....	26
Counting direction.....	27
Absolute resolution	27
Preset / Offset	27
Device type	29
SINE / COSINE resolution	29
Position control	29
Device ID	29
Manufacturer ID	29
6.6 Application note.....	30
6.7 Examples.....	30
6.7.1 Setting the Configuration register (49).....	30
6.7.2 Setting the Preset / Offset registers (51-53).....	31
6.8 Recommended BiSS input circuit.....	31
7 – AB incremental output signals	32
7.1 Recommended input circuit.....	34
8 – Error and fault diagnostics	35
9 – Maintenance	36
10 – Troubleshooting	37
11 – Default parameters list	38

Subject index



A		N	
Absolute resolution.....	27	Normal operation.....	25
C		O	
Command.....	25	Offset.....	28
Configuration.....	26	Output code.....	26
Counting direction.....	27	P	
D		Position control.....	29
Device ID.....	29	Preset.....	28
Device type.....	29	Preset / Offset.....	27
E		Profile ID.....	24
Enable preset / offset.....	26	S	
L		Save and activate Preset / Offset.....	25
Load and save default parameters.....	25	Save parameters on EEPROM.....	25
M		Serial number.....	25
Manufacturer ID.....	29	Set preset / offset.....	26
		SINE / COSINE resolution.....	29

Typographic and iconographic conventions

In this guide, to make it easier to understand and read the text the following typographic and iconographic conventions are used:

- parameters and objects both of the device and the interface are coloured in **GREEN**;
- alarms are coloured in **RED**;
- states are coloured in **FUCSIA**.

When scrolling through the text some icons can be found on the side of the page: they are expressly designed to highlight the parts of the text which are of great interest and significance for the user. Sometimes they are used to warn against dangers or potential sources of danger arising from the use of the device. You are advised to follow strictly the instructions given in this guide in order to guarantee the safety of the user and ensure the performance of the device. In this guide the following symbols are used:

	This icon, followed by the word WARNING , is meant to highlight the parts of the text where information of great significance for the user can be found: user must pay the greatest attention to them! Instructions must be followed strictly in order to guarantee the safety of the user and a correct use of the device. Failure to heed a warning or comply with instructions could lead to personal injury and/or damage to the unit or other equipment.
	This icon, followed by the word NOTE , is meant to highlight the parts of the text where important notes needful for a correct and reliable use of the device can be found. User must pay attention to them! Failure to comply with instructions could cause the equipment to be set wrongly: hence a faulty and improper working of the device could be the consequence.
	This icon is meant to highlight the parts of the text where suggestions useful for making it easier to set the device and optimize performance and reliability can be found. Sometimes this symbol is followed by the word EXAMPLE when instructions for setting parameters are accompanied by examples to clarify the explanation.

Preliminary information

This guide is designed to provide the most complete and exhaustive information the operator needs to correctly and safely install and operate the **SMA2 series absolute linear encoder**. SMA2 is designed to measure displacements in industrial machines and automation systems. The measurement system includes a magnetic tape and a magnetic sensor with conversion electronics. The scale is magnetized with a coded sequence of North-South poles and can be fitted with two tracks: an absolute track on one side and an incremental track on the other side (on specific models only). As the encoder moves along the magnetic scale, the sensor detects the displacement and yields the absolute position information through the SSI interface (order code SMA2-GG1-..., SMA2-G11-... and SMA2-BG1-...) or the BiSS C-mode interface (order code SMA2-SC1-...). In specific version the encoder can further provide additional AB incremental signals for speed feedback through the NPN o.c. output circuit. It is mandatory to pair the sensor with the **MTA2 type magnetic tape**.

To make it easier to read and understand the text, this guide can be divided into four main sections. In the first section some general information concerning the safety, the mechanical installation and the electrical connection as well as tips for setting up and running properly and efficiently the unit are provided. In the second section, entitled **SSI interface**, both general and specific information is given on the SSI interface. In the third section, entitled **BiSS C-mode interface**, both general and specific information is given on the BiSS C-mode interface. In this section the parameters implemented in the unit are fully described. Finally, in the fourth section, entitled **AB incremental output signals**, some information is given on the additional incremental signals.

1 - Safety summary

1.1 Safety

- Always adhere to the professional safety and accident prevention regulations applicable to your country during device installation and operation;
- installation and maintenance operations have to be carried out by qualified personnel only, with power supply disconnected and stationary mechanical parts;
- device must be used only for the purpose appropriate to its design: use for purposes other than those for which it has been designed could result in serious personal and/or the environment damage;
- high current, voltage and moving mechanical parts can cause serious or fatal injury;
- warning ! Do not use in explosive or flammable areas;
- failure to comply with these precautions or with specific warnings elsewhere in this manual violates safety standards of design, manufacture, and intended use of the equipment;
- Lika Electronic assumes no liability for the customer's failure to comply with these requirements.

1.2 Electrical safety

- Turn OFF power supply before connecting the device;
- connect the unit according to the explanation in the "4 - Electrical connections" section;
- the wires of unused signals must be cut at different lengths and insulated singularly;
- in compliance with 2014/30/UE norm on electromagnetic compatibility, following precautions must be taken:
 - before handling and installing the equipment, discharge electrical charge from your body and tools which may come in touch with the device;
 - power supply must be stabilized without noise; install EMC filters on device power supply if needed;
 - always use shielded cables (twisted pair cables whenever possible);
 - avoid cables runs longer than necessary;
 - avoid running the signal cable near high voltage power cables;
 - mount the device as far as possible from any capacitive or inductive noise source; shield the device from noise source if needed;
 - to guarantee a correct working of the device, avoid using strong magnets on or near by the unit;
 - minimize noise by connecting the cable shield (or the connector housing) and the sensor to ground. Make sure that ground is not affected by noise. The connection point to ground can be situated both on the device side and on user's side. The best solution to minimize the interference must be carried out by the user.
- do not stretch the cable; do not pull or carry by cable; do not use the cable as a handle.



1.3 Mechanical safety

- Install the device following strictly the information in the "3 - Mounting instructions" section;
- mechanical installation has to be carried out with stationary mechanical parts;
- do not disassemble the unit;
- do not tool the unit;
- delicate electronic equipment: handle with care; do not subject the device to knocks or shocks;
- protect the unit against acid solutions or chemicals that may damage it;
- respect the environmental characteristics of the product;
- we suggest installing the unit providing protection means against waste, especially swarf as turnings, chips, or filings; should this not be possible, please make sure that adequate cleaning measures (as for instance brushes, scrapers, jets of compressed air, etc.) are in place in order to prevent the sensor and the magnetic scale from jamming.

2 - Identification

Device can be identified through the **order code** and the **serial number** printed on the label applied to its body. Information is listed in the delivery document too. Please always quote the order code and the serial number when reaching Lika Electronic for purchasing spare parts or needing assistance. For any information on the technical characteristics of the product refer to the technical datasheet.



Warning: devices having order code ending with "/Sxxx" may have mechanical and electrical characteristics different from standard and be supplied with additional documentation for special connections (Technical Info).

3 - Mounting instructions



WARNING

Installation has to be carried out by qualified personnel only, with power supply disconnected and mechanical parts compulsorily in stop.

3.1 Overall dimensions

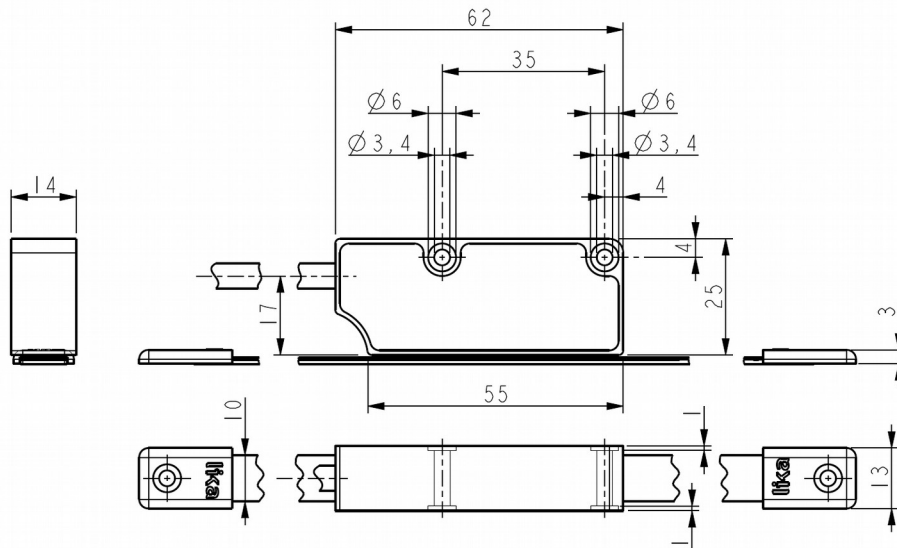

3.2 Magnetic scale

The sensor has to be paired with the **MTA2 type magnetic scale** only. For detailed information on the MTA2 type scale and how to mount it refer to the specific technical documentation.

Install the unit providing protection means against waste, especially swarf as turnings, chips, or filings; should this not be possible, please make sure that adequate cleaning measures (as for instance brushes, scrapers, jets of compressed air, etc.) are in place in order to prevent the sensor and the magnetic scale from jamming.

Make sure the mechanical installation meets the system's requirements of distance, planarity and parallelism between the sensor and the scale indicated in Figure 2 all along the whole measuring length.

The Figure 1 shows how the sensor and the scale must be installed; please note that the MTA2 magnetic scale can be fitted with two tracks: an absolute track on one side and an incremental track on the other side. Thus you must strictly comply with the mounting direction!

MTA2 magnetic scale can be provided with a cover strip to protect its magnetic surface (see the order code).

The arrow indicates the **standard counting direction** (increasing count with sensor moving as indicated by the arrow in the Figure; for the BiSS version see the parameter **Counting direction** on page 27; the counting direction function is not available for the SSI interface).



WARNING

The system cannot work if mounted otherwise than illustrated in Figure 1.

3.3 Mounting the sensor

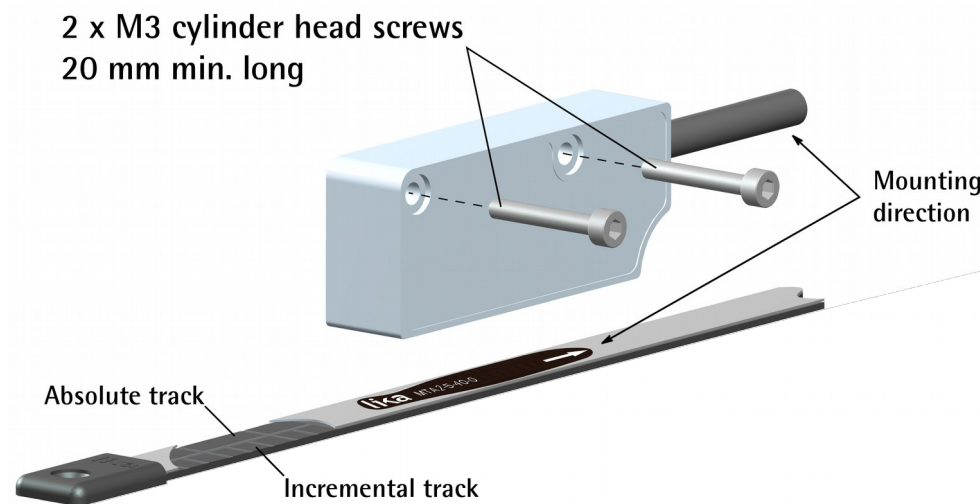

Figure 1

Make sure the mechanical installation complies with the system requirements concerning distance, planarity and parallelism between the sensor and the scale as shown in Figure 2. Avoid contact between the parts. Fix the sensor by means of **two M3 20 mm min. long cylinder head screws** inserted in the provided holes. Recommended tightening torque: **1.1 Nm**. Recommended **minimum bend radius** of the cable: **R ≥ 42 mm**.

Please note that the MTA2 magnetic scale can be provided with a cover strip to protect its magnetic surface (see the order code). Therefore the distance between the sensor and the magnetic scale is different whether the cover strip is applied.

The allowed gap D (see Figure 2) between the sensor and the scale must be in the range indicated in the following table:

Gap sensor / MTA2 magnetic scale (D)	
without cover strip	with cover strip
0.1 – 0.6 mm / 0.004" – 0.024"	0.1 – 0.4 mm / 0.004" – 0.016"



WARNING

Make sure the mechanical installation complies with the system requirements concerning distance, planarity and parallelism between the sensor and the scale as shown in Figure 2 all along the whole measuring length.

Please note that the MTA2 magnetic scale can be fitted with two tracks: an absolute track on one side and an incremental track on the other side. Thus you must strictly comply with the mounting direction!

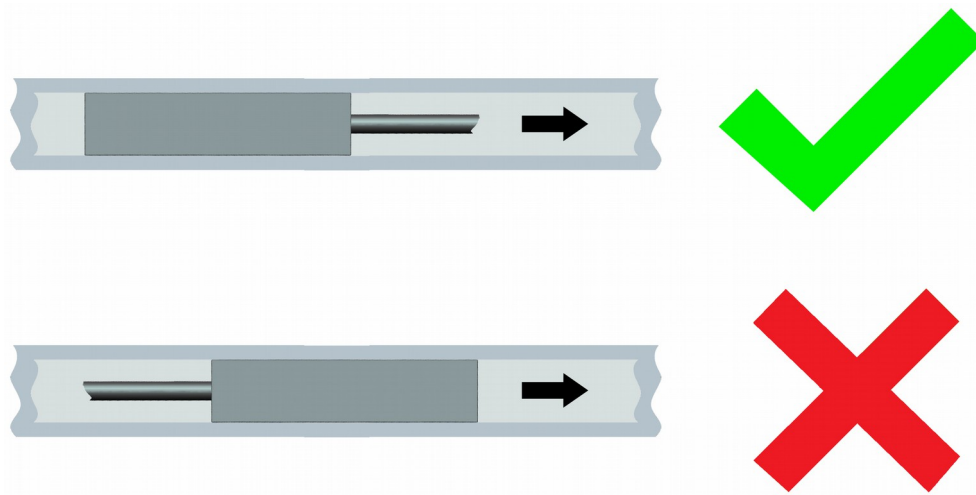

Distance from the scale

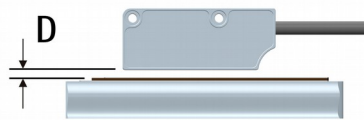

Lateral deviation

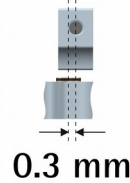

Roll

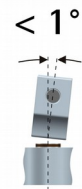

Tilt

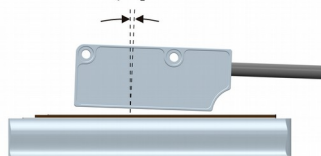

Yaw

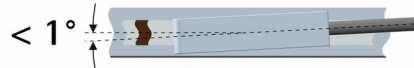

Figure 2



WARNING

After having installed the sensor on the magnetic scale a zero setting / Preset operation is compulsorily required. The zero setting / Preset operation is further required every time either the sensor or the scale is replaced. The zero setting / Preset function is available for the BiSS interface only, refer to page 27. It is not available for the SSI interface (SMA2-BG1-..., SMA2-GG1-..., SMA2-G11-...).

4 - Electrical connections



WARNING

Electrical connection has to be carried out by qualified personnel only, with power supply disconnected and mechanical parts compulsorily in stop.



WARNING

If wires of unused signals come in contact, irreparable damage could be caused to the device. Please insulate them singularly.

Connections

Function	M12 8-pin	M8 cable
0Vdc power supply	1	Black
+5Vdc \pm 5% power supply	2	Red
Clock IN + / MA +	3	Yellow
Clock IN - / MA -	4	Blue
Data OUT + / SLO +	5	Green
Data OUT - / SLO -	6	Orange
A ¹	7	White
B ¹	8	Grey
Shield	Case	Shield

- 1 AB incremental output signals are provided in specific versions only, see the order code: SMA2-G11-... (= SSI interface, MSB Left Aligned protocol, Gray output code, + AB incremental); SMA2-SC1-... (BiSS interface, C protocol + AB incremental). For any information please refer to the "7 - AB incremental output signals" section on page 32.

4.1 M12 8-pin connector specifications

M12 8-pin connector
male, frontal side
A coding

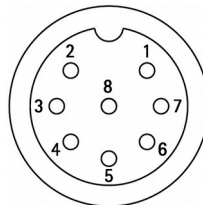

4.2 M8 cable specifications

Model : LIKA HI-FLEX M8 cable
 Wires : 6 x 0.14 mm² + 2 x 0.22 mm²
 Shield : tinned copper braid
 External diameter : \varnothing 5.3 mm \div 5.6 mm
 Conductor resistance : <148 Ω /km (0.14 mm²); <90 Ω /km (0.22 mm²)
 Minimum bend radius : \varnothing x 7.5

4.3 Ground connection

Minimize noise by connecting the cable shield (or the connector housing) and the sensor to ground. Make sure that ground is not affected by noise. The connection point to ground can be situated both on the device side and on user's side. The best solution to minimize the interference must be carried out by the user.

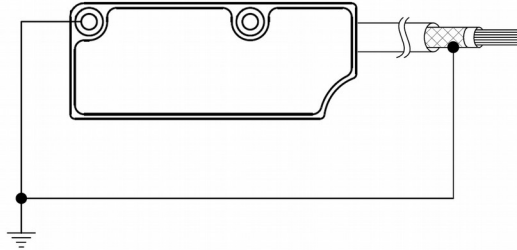

4.4 AB incremental output signals

For any information on the AB incremental output signals refer to the "7 – AB incremental output signals" section on page 32. AB incremental output signals are provided in specific versions only, see the: SMA2-G11-... and SMA2-SC1-... order codes.

4.5 Features summary

Order code	Resolution μm	Max. travel speed m/s
SMA2-xx1-50-...	50	7
SMA2-xx1-10-...	10	7
SMA2-xx1-5-...	5	7
SMA2-xx1-2-...	2	2.8
SMA2-xx1-1-...	1	1.4

Max. scale length (max. measuring length)	8,220 mm (8,165 mm)
Pole pitch dimension	2 mm
Max. information (max. value)	23 bits (8,388,607)

5 - SSI interface

Order codes: SMA2-BG1-...
 SMA2-GG1-...
 SMA2-G11-...

5.1 SSI (Synchronous Serial Interface)



SSI (the acronym for **Synchronous Serial Interface**) is a synchronous point-to-point serial interface engineered for unidirectional data transmission between one Master and one Slave. Developed in the first eighties, it is based on the RS-422 serial standard. Its most peculiar feature is that data transmission is achieved by synchronizing both the Master and the Slave devices to a common clock signal generated by the controller; in this way the output information is clocked out at each controller's request. Furthermore only two pairs of twisted wires are used for data and clock signals, thus a six-wire cable is required.

The main advantages in comparison with parallel or asynchronous data transmissions are:

- less conductors are required for transmission;
- less electronic components;
- possibility of insulating the circuits galvanically by means of optocouplers;
- high data transmission frequency;
- hardware interface independent from the resolution of the absolute encoder.

Furthermore the differential transmission increases the noise immunity and decreases the noise emissions. It allows multiplexing from several encoders, thus process controls are more reliable with simplified line design and easier data management.

Data transmission is carried out as follows.

At the first falling edge of the clock signal (1, the logic level changes from high to low) the absolute position value is stored while at the following rising edge (2) the transmission of data information begins starting from the MSB.

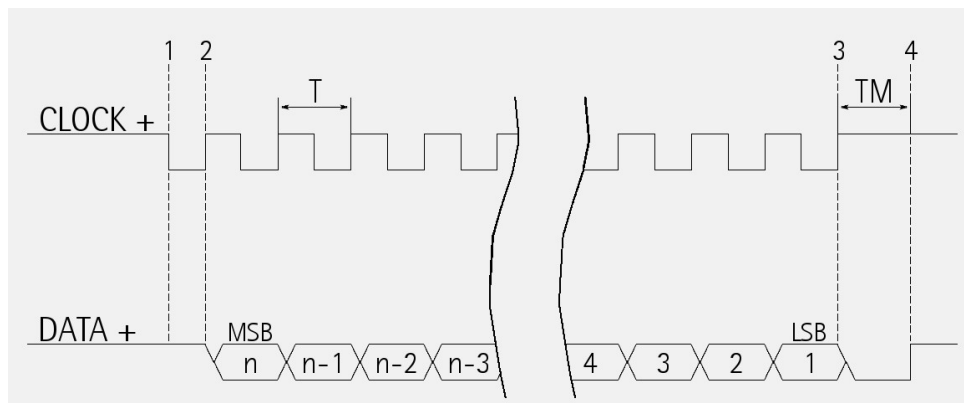

At each change of the clock signal and at each subsequent rising edge (2) one bit is clocked out at a time, up to LSB, so completing the data word transmission. The cycle ends at the last rising edge of the clock signal (3). This means that up to $n + 1$ rising edges of the clock signals are required for each data word transmission (where n is the bit resolution); for instance, a 13-bit encoder needs 14 clock edges. If the number of clocks is greater than the number of bits of the data word, then the system will send a zero (low logic level signal) at each additional clock, zeros will either lead (LSB ALIGNED protocol) or follow (MSB ALIGNED protocol) or lead and/or follow (TREE FORMAT protocol) the data word. After the period T_m monoflop time, having a typical duration of 12 μ sec, calculated from the end of the clock signal transmission, the encoder is then ready for the next transmission and therefore the data signal is switched high.

The clock signal has a typical logic level of 5V, the same as the output signal which has customarily a logic level of 5V in compliance with RS-422 standard. The output code can be either Binary or Gray (see the order code).

5.2 "MSB left aligned" protocol

"MSB left aligned" protocol allows to left align the bits, beginning from MSB (most significant bit) to LSB (least significant bit); MSB is then sent at the first clock cycle. If the number of clock signals is higher than the data bits, then unused bits are forced to logic level low (0) and follow the data word. This protocol can be used in sensors having any resolution. The number of clocks to be sent to the sensor must equal the number of data bits at least, anyway it can be higher, as stated previously. The great advantage of this protocol over the TREE format or the LSB RIGHT ALIGNED format is that data can be transmitted with a minimum time loss and T_m monoflop time can immediately follow the data bits without any additional clock signal.

The device uses a variable number of bits to provide the position information, according to the resolution, as shown in the following table.

Model	Resolution	Length of the word	Max. number of information
SMA2-BG1-50-... SMA2-GG1-50-... SMA2-G11-50-...	50 μ m	19 bits	18 bits (262143)
SMA2-BG1-10-... SMA2-GG1-10-... SMA2-G11-10-...	10 μ m	21 bits	20 bits (1048575)
SMA2-BG1-5-... SMA2-GG1-5-... SMA2-G11-5-...	5 μ m	22 bits	21 bits (2097151)
SMA2-BG1-2-... SMA2-GG1-2-... SMA2-G11-2-...	2 μ m	23 bits	22 bits (4194303)

SMA2-BG1-1-... SMA2-GG1-1-... SMA2-G11-1-...	1 μm	24 bits	23 bits (8388607)
--	------	---------	-------------------

The output code can be GRAY or BINARY (see the order code).
The length of each information is equal to the resolution.

Structure of the position information

SMA2-BG1-50-... SMA2-GG1-50-... SMA2-G11-50-...	bit	19	...	2	1
SMA2-BG1-10-... SMA2-GG1-10-... SMA2-G11-10-...	bit	21	...	2	1
SMA2-BG1-5-... SMA2-GG1-5-... SMA2-G11-5-...	bit	22	...	2	1
SMA2-BG1-2-... SMA2-GG1-2-... SMA2-G11-2-...	bit	23	...	2	1
SMA2-BG1-1-... SMA2-GG1-1-... SMA2-G11-1-...	bit	24	...	2	1
	value	MSB	...	LSB	Error bit



WARNING

The position value issued by the sensor is expressed in pulses; to convert the pulses into a metric measuring unit you must multiply the number of detected pulses by the resolution.



EXAMPLE 1

SMA2-BG1-50-...
resolution = 50 μm
detected pulses = 123
position value = 123 * 50 = 6150 μm = 6.15 mm



EXAMPLE 2

SMA2-BG1-1-...
resolution = 1 μm
detected pulses = 1569
position value = 1569 * 1 = 1569 μm = 1.569 mm

5.3 Recommended transmission rates

The SSI interface has a frequency of data transmission ranging between 100 kHz and 1 MHz.

The CLOCK signal and DATA signal comply with the "EIA standard RS-422".

The SSI clock frequency (baud rate) depends on the length of the cable and must comply with the technical information reported in the following table:

Cable length	Baud rate
< 50 m	< 400 kHz
< 100 m	< 300 kHz
< 200 m	< 200 kHz
< 400 m	< 100 kHz

The time interval between two Clock sequence transmissions must be at least 16 μ s ($T_p > 16 \mu$ s).

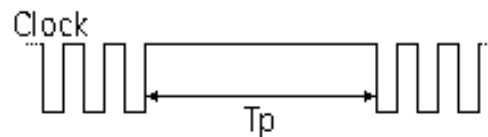

5.4 Error bit

The error bit is intended to communicate the normal or fault status of the Slave.

"1": correct status (no active error)

"0": an error is active:

- reading error: the sensor is not able to read the scale correctly; among the possible causes are: the scale is not installed properly (for instance: the scale is mounted contrariwise to the sensor; or it is mounted upside down; see the "3 - Mounting instructions" section on page 10); the scale magnetic surface is damaged somewhere; the sensor is not working properly;
- frequency error: the sensor is travelling too fast on the scale.



NOTE

For any information on the structure of the position information word, please refer to the "5.2 "MSB left aligned" protocol" section on page 16.

5.5 Helpful information

- The zero setting / Preset and Counting direction functions are not available.
- The position information increases when the sensor moves as indicated by the arrow in Figure 1, starting from a min. value up to a max. value; min. and max. values depend on the specific MTA2 magnetic scale installed in your application.
- If required by your application, at installation execute a zero setting / Preset operation of the position read by the Master.

5.6 Recommended SSI input circuit

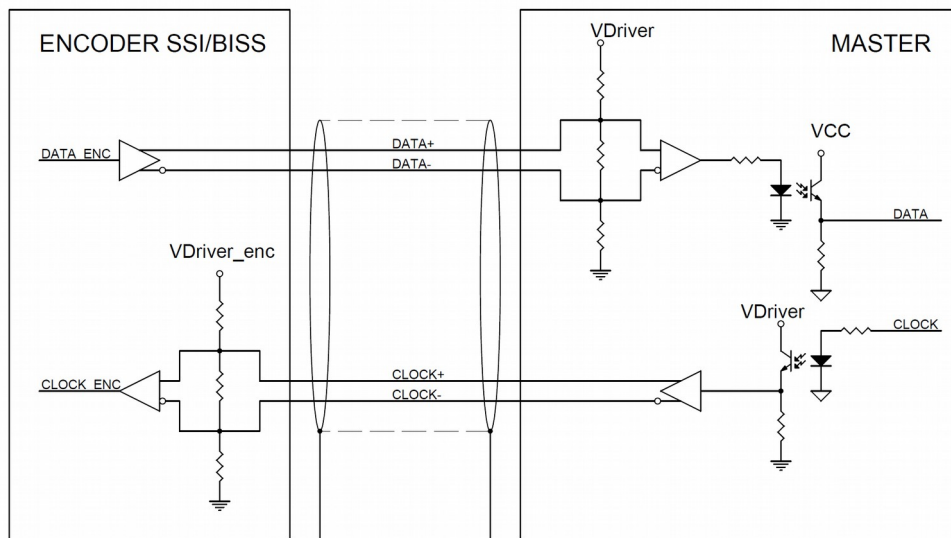

6 - BiSS C-mode interface

Order code: standard SMA2-SC1-...

SMA2 is a Slave device and complies with the "BiSS C-mode interface" and the "Standard encoder profile".

For detailed information not listed in this manual please refer to the official BiSS website (www.biss-interface.com).

The device is designed to operate in a point-to-point configuration and has to be installed in a "single Master - single Slave" network.



WARNING

Never connect the sensor in a "single Master - Multi Slave" network.

CLOCK MA and DATA SLO signal levels comply with the "RS-422 EIA standard".

6.1 XML file

The product is supplied with an XML file **idbiss4C69.xml** (see at the address www.lika.biz > **LINEAR ENCODERS** > **ABSOLUTE MAGNETIC SENSORS** > **SMA2**). Install the XML file in your BiSS Master device.

6.2 Communication

The BiSS C-mode protocol uses two types of data transmission protocols:

- **Single Cycle Data (SCD):** this is the primary data transmission protocol. It is used to transmit the process data from the Slave device to the Master device. See the "6.3 Single Cycle Data" section on page 21.
- **Control Data (CD):** transmission of a single bit following the SCD data. It is used to read data from or write data to the registers of the Slave. See the "6.4 Control Data CD" section on page 22.

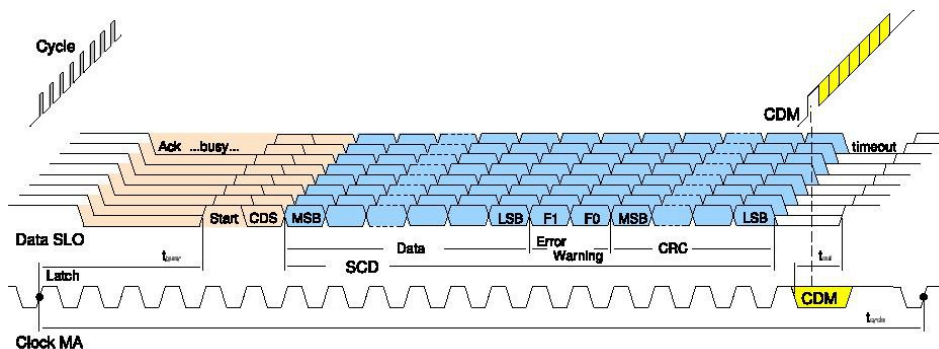

6.3 Single Cycle Data

SCD (32 bits) consists of the following values: 24-bit position value (**Position**), 1 error bit (**Error**, nE), 1 warning bit (**Warning**, nW) and CRC checking (**CRC**, 6 bits).

SCD structure:

bits	31...8	7	6	5...0
function	Position	Error	Warning	CRC

Position

(24 bits)

Process data to be transmitted from the Slave to the Master.

The transmission starts with the MSB (most significant bit) and ends with the LSB (least significant bit).

bit	31 ... 28	27	...	8
value	0000	MSB	...	LSB

To convert the position value into microns or millimetres, multiply the received data value by the resolution (see 4Dhex **Absolute resolution** register).



EXAMPLE 1

SMA2-SC1-50-..., **Absolute resolution** = 32 hex, 50 µm
 detected pulses = 123
 position value = 123 * 50 = 6150 µm = 6.15 mm



EXAMPLE 2

SMA2-SC1-1-..., **Absolute resolution** = 01 hex, 1 µm
 detected pulses = 1569
 position value = 1569 * 1 = 1569 µm = 1.569 mm

Error

(1 bit)

This is intended to communicate the normal or fault status of the Slave.

nE = "1": correct status (no active error)

= "0": error status: an error is active:

- reading error: the sensor is not able to read the scale correctly; among the possible causes are: the scale is not installed properly (for instance: the scale is mounted contrariwise to the sensor; or it is mounted upside down; see the "3 - Mounting instructions" section on page 10); the scale magnetic surface is damaged somewhere; the sensor is not working properly;
- frequency error: the sensor is travelling too fast on the scale.

Warning

(1 bit)

This is used along with the **Position control** register (see on page 29) to perform an automatic position control.



WARNING

The use of both the **Position control** register and this **Warning** bit is strictly reserved to Lika Electronic technicians.

CRC

(6 bits)

CRC, namely Cyclic Redundancy Check, is the error checking field resulting from a "Redundancy Check" calculation performed on the message contents. This is intended to check whether transmission has been performed properly (inverted output).

Polynomial: X^6+X^1+1 (binary: 1000011)

Logic circuit:

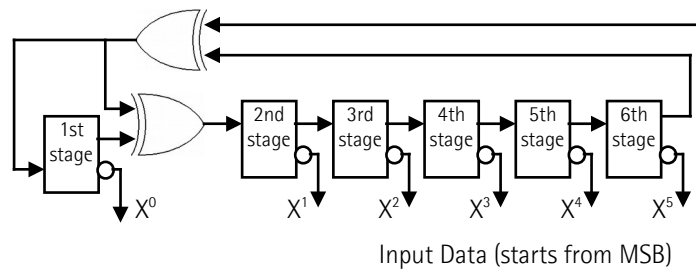

6.4 Control Data CD

For complete CD structure information please refer to the official BiSS documents: "Protocol description C-mode".

Main control data is described in this section.

Register address

(7 bits)

This is the address of the register; it specifies the register you need to read from or write to.

RW

(2 bits)

It sets whether you need to write to the register (**RW** = "01") or to read from the register (**RW** = "10").

RW = "01" : when you need to write to the register

RW = "10" : when you need to read from the register

DATA

(8 bit)

When writing to the register (**RW** = "01"): this is the value to be set in the register (i.e. transmitted from the Master to the Slave).

When reading from the register (**RW** = "10"): this is the value to be read in the register (i.e. transmitted from the Slave to the Master).

Data bit structure:

bit	7	0
	MSB	LSB

CRC

(4 bits)

CRC, namely Cyclic Redundancy Check, is the error checking field resulting from a "Redundancy Check" calculation performed on the message contents. This is intended to check whether transmission has been performed properly (inverted output).

Polynomial: X^4+X^1+1 (binary: 10011)

Logic circuit:

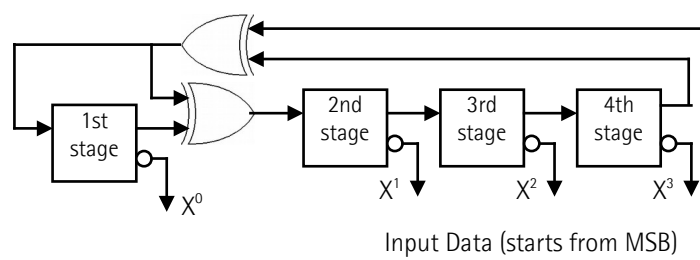

6.5 Used registers

Register (hex)	Function
42 - 43	Profile ID
44 ... 47	Serial number
48	Command
49	Configuration
4D	Absolute resolution
51 ... 53	Preset / Offset
55	Device type
58	SINE / COSINE resolution
59	Position control
78 ... 7D	Device ID
7E - 7F	Manufacturer ID

All registers in this section are listed according to the following scheme:

Function name

[Address, access]

Description of the function and default value.

- Address: register address expressed in hexadecimal notation.
- Access: ro = read only
 rw = read and write
 wo = write only
- Default parameter values are written in **bold**.

Profile ID

[42 - 43, ro]

These registers contain the identification code of the used profile.

Register	42	43	
Hex	28	12	SMA2-SC1-50-...
		14	SMA2-SC1-10-...
		15	SMA2-SC1-5-...
		16	SMA2-SC1-2-...
		17	SMA2-SC1-1-...

See "Standard encoder profile", "data format", "Variant 0-24".

Serial number**[44 ... 47, ro]**

These registers show the serial number of the device expressed in hexadecimal notation.

Register 44 : year of production

Register 45 : week of production

Registers 46 and 47 : serial number in ascending order

Command**[48, wo]**

Value	Function
00	Normal operation
01	Save parameters on EEPROM
02	Save and activate Preset / Offset
04	Load and save default parameters

After having set a new value in some register, use the **Save parameters on EEPROM** function in this register to store it. Set "01" in the register.

After having set a Preset / Offset value, use the **Save and activate Preset / Offset** function in this register to both store and activate the preset / offset at the same time. Set "02" in the register.

Load and save default parameters: default parameters are set at the factory by Lika Electronic engineers to allow the operator to run the device for standard operation in a safe mode. As soon as the command is sent the default parameters are uploaded and activated. All parameters which have been set previously are overwritten, thus previously set values are lost. The complete list of machine data and the relevant default parameters preset by Lika Electronic engineers are available on page 38. Set "04" in the register.

**WARNING**

As soon as the **Load and save default parameters** command is sent, all parameters which have been set previously are overwritten, thus previously set values are lost!

As soon as the command is sent, the register is set back to "00" (**Normal operation**) automatically.

Wait min. 30 ms (EEPROM writing time) before using a new function.

Default = 00 (**Normal operation**)

Configuration

[49, rw]

Bit	Function	bit=0	bit=1
0	Not used		
1	Set preset / offset	Preset	Offset
2	Enable preset / offset	Enable	Disable
3	Not used		
4	Not used		
5	Output code	Gray	Binary
6	Counting direction *	Standard	Inverted
7	Not used		

*: it affects the absolute position information, not the AB incremental signals

Set preset / offset

This parameter is available only if the **Enable preset / offset** parameter is set to ENABLE. It allows to activate either the preset function (**Set preset / offset** = PRESET) or the offset function (**Set preset / offset** = OFFSET); the Preset or Offset value has to be set in the **Preset / Offset** register. After having enabled the preset / offset functions (**Enable preset / offset** = ENABLE), this item allows to activate either the preset function or the offset function. The value set in the **Preset / Offset** register will have a different meaning depending on the value of this parameter whether it is set to PRESET (0) or OFFSET (1). In the first case (**Set preset / offset** = PRESET) the **Preset / Offset** register is used to set the preset value; while in the second case (**Set preset / offset** = OFFSET) the **Preset / Offset** register is used to set the offset value. To activate the preset / offset value use the **Save and activate Preset / Offset** function in the **Command** register (set "02" in the register 48).

For any information on the preset and offset functions refer to the **Preset / Offset** register on page 27.

Default = 0 (Preset)

Enable preset / offset

It enables / disables the preset / offset functions. After having enabled the use of the functions you have to choose whether to activate the preset or the offset in the **Set preset / offset** parameter. Then to activate a new value, set it next to the **Preset / Offset** register and send the **Save and activate Preset / Offset** command (set "02" in the register 48).

Default = 0 (enable)

Output code

The sensor provides the absolute position information in the desired code format: GRAY (0) or BINARY (1).

Default = 1 (Binary)

Counting direction

The **standard counting direction** is to be intended with sensor moving as indicated by the arrow in Figure 1. This parameter allows to reverse the counting direction. In other words it allows the count up when the sensor moves in the reverse of the standard direction, i.e. in the opposite direction to the one shown by the arrow in Figure 1. It is possible to choose the following options: STANDARD (0) and INVERTED (1). When the counting direction is set to STANDARD -**Counting direction** = STANDARD-, the position information increases when the sensor moves according to the arrow in Figure 1. When the option INVERTED is set -**Counting direction** = INVERTED-, the position information increases when the sensor moves in reverse of the standard direction, i.e. in the opposite direction to the one shown by the arrow in Figure 1.

Default = 0 (Standard)



NOTE

The **Counting direction** parameter affects the absolute position information, not the AB incremental signals.

The new setting will be active immediately after transmission. Use the **Save parameters on EEPROM** function (set "01" in the register 48) to store the new value.

Configuration register default value = 20h

Absolute resolution

[4D, ro]

It allows to read the resolution of the absolute sensor.

32hex :	Resolution = 50 μ m	(max position = 03 FF FFh, 18 bits)
0Ahex :	Resolution = 10 μ m	(max position = 0F FF FFh, 20 bits)
05hex :	Resolution = 5 μ m	(max position = 1F FF FFh, 21 bits)
02hex :	Resolution = 2 μ m	(max position = 3F FF FFh, 22 bits)
01hex :	Resolution = 1 μ m	(max position = 7F FF FFh, 23 bits)

Preset / Offset

[51 ... 53, rw]

This function is available only if the **Enable preset / offset** parameter in the **Configuration** register is set to ENABLE. Furthermore it has a double function depending on whether the **Set preset / offset** parameter in the **Configuration** register is set to PRESET or OFFSET. In the first case (**Set preset / offset** = PRESET) the **Preset / Offset** register is used to set the preset value; while in the second case (**Set preset / offset** = OFFSET) the **Preset / Offset** register is used to set the offset value.



WARNING

Activate the preset / offset value only when the device is not moving.

Preset

The Preset function is meant to assign a value to a desired physical position of the sensor. The chosen physical position will get the value set next to this item and all the previous and following positions will get a value according to it. This function is useful, for example, when the zero position of the sensor and the zero position of the axis need to match. The preset value will be set for the position of the sensor in the moment when the preset value is activated. To activate the preset, stop the sensor in the desired position, enter the desired value next to this **Preset / Offset** register and then send the **Save and activate Preset / Offset** command in the **Command** register (set "02" in the register 48).

Offset

The offset function is meant to assign a value to a desired physical position of the sensor so that the output position information is shifted according to the value next to this **Preset / Offset** register. The number of transmitted values will match the max number of position information as per the set resolution, but the output information will range between the **Preset / Offset** value (minimum value) and the sum of the max. position information as per the set resolution (see the **Absolute resolution** register) + the **Preset / Offset** value (maximum value). The offset value will be set for the position of the sensor in the moment when the offset value is activated. To activate the offset, stop the sensor to the desired position, enter the desired value next to this **Preset / Offset** register and then send the **Save and activate Preset / Offset** command in the **Command** register (set "02" in the register 48).

Preset / Offset structure:

Reg.	51	52	53
	MSB	...	LSB
	$2^{23} - 2^{16}$	$2^{15} - 2^8$	$2^7 - 2^0$

Use the **Save and activate Preset / Offset** function (set "02" in the register 48) to store and activate the new value.

The max. allowed Preset value depends on the set resolution:

- resolution = 50 µm → max preset = 03 FF FFh (18 bits)
- resolution = 10 µm → max preset = 0F FF FFh (20 bits)
- resolution = 5 µm → max preset = 1F FF FFh (21 bits)
- resolution = 2 µm → max preset = 3F FF FFh (22 bits)
- resolution = 1 µm → max preset = 7F FF FFh (23 bits)

The Offset value must be less than or equal to the difference between the overall position information (24 bits, see **Position**) and the max. position information allowed by the set resolution (see the **Absolute resolution** register).

Default = **00h**.

Device type**[55, ro]**

This register describes the type of device.

Default = **07h**: BiSS linear encoder + AB incremental signal**SINE / COSINE resolution****[58, ro]**

This register describes the period of the sine/cosine signal.

Default = **00h**: the register is not used**Position control****[59, rw]**This is used along with the **Warning** bit (see on page 22) to perform an automatic position control.Default = **00h****WARNING**

Do not change the value in this register, its use is strictly reserved to Lika Electronic technicians.

Device ID**[78 ... 7D, ro]**

These registers show the Device ID, hexadecimal values are according to ASCII code.

Reg.	78	79	7A	7B	7C	7D
Hex	53	4D	41	32	xx	xx
ASCII	S	M	A	2	-	-

xx: software version

Manufacturer ID**[7E – 7F, ro]**

These registers show the Manufacturer ID, hexadecimal values are according to ASCII code.

Reg.	7E	7F
Hex	4C	69
ASCII	L	i

Li = Lika Electronic.

6.6 Application note

Device communication specifications:

Parameter	Value
Clock Frequency	min 200 kHz, max 10 MHz
BiSS Timeout	auto adaptation to clock, max 16 μ s
Internal position update frequency	30 kHz

6.7 Examples

All values are expressed in hexadecimal notation, unless otherwise indicated.



6.7.1 Setting the Configuration register (49)

Bit 0	= not used	= 0
Bit 1 Set preset / offset	= PRESET	= 0
Bit 2 Enable preset / offset	= ENABLE	= 0
Bit 3	= not used	= 0
Bit 4	= not used	= 0
Bit 5 Output code	= BINARY	= 1
Bit 8 Counting direction	= INVERTED	= 1
Bit 7	= not used	= 0

$01100000_2 = 60$ hex

Function	ADR	DATA Tx
writing the Configuration register	49	60
Save parameters on EEPROM	48	01



6.7.2 Setting the Preset / Offset registers (51-53)

After having enabled and chosen the PRESET function (**Enable preset / offset** = ENABLE; **Set preset / offset** = PRESET in the **Configuration** register, see the previous "6.7.1 Setting the Configuration register (49)") section, you want to set and activate the new Preset value = $100000_{10} = 01\ 86\ A0h$

Function	ADR	DATA Tx
writing the Preset / Offset registers	51	01
	52	86
	53	A0
Save and activate Preset / Offset	48	02

6.8 Recommended BiSS input circuit

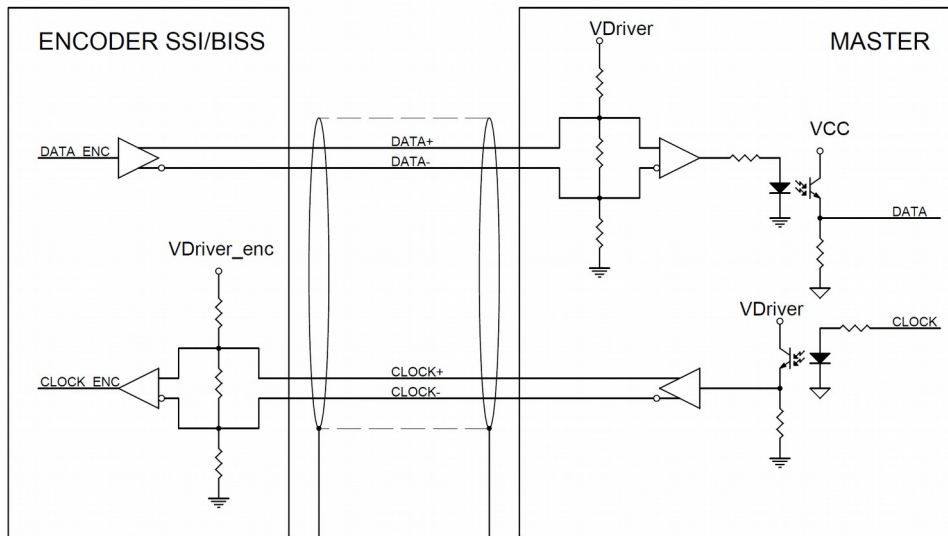

7 – AB incremental output signals



WARNING

AB incremental output signals are provided in specific versions only, see the order code: SMA2-G11-... (= SSI interface, MSB Left Aligned protocol, Gray output code, + AB incremental); SMA2-SC1-... (BiSS interface, C protocol + AB incremental).

In addition to the absolute position information, SMA2 sensor can provide two AB incremental signals through the NPN open collector output circuit.

They require +5Vdc $\pm 5\%$ power supply with $I_{out} = 40$ mA max.

Thermal and short-circuit protections are not provided.

Please note that in this case the MTA2 magnetic scale is fitted with two tracks: an absolute track on one side and an incremental track on the other side. Thus you must strictly comply with the mounting direction! For complete information refer to the "3 - Mounting instructions" section on page 10 and to the "4 - Electrical connections" section on page 13.

In the following table the main features of the incremental measuring system are listed for each order code. They concern the resolution (i.e. the distance between two following edges of A and B channels); the minimum edge distance (i.e. the minimum spacing between two following signal edges at output, the maximum counting frequency and the maximum travel speed.

Order code	Resolution μm	Minimum edge distance μs^*	Max. AB frequency kHz	Max. travel speed m/s
SMA2-G11-50-... SMA2-SC1-50-...	50	0.25	73	7
SMA2-G11-10-... SMA2-SC1-10-...	10	0.25	350	7
SMA2-G11-5-... SMA2-SC1-5-...	5	0.25	580	7
SMA2-G11-2-... SMA2-SC1-2-...	2	0.25	580	2.8
SMA2-G11-1-... SMA2-SC1-1-...	1	0.25	580	1.4

* Max. counting frequency = 4 MHz

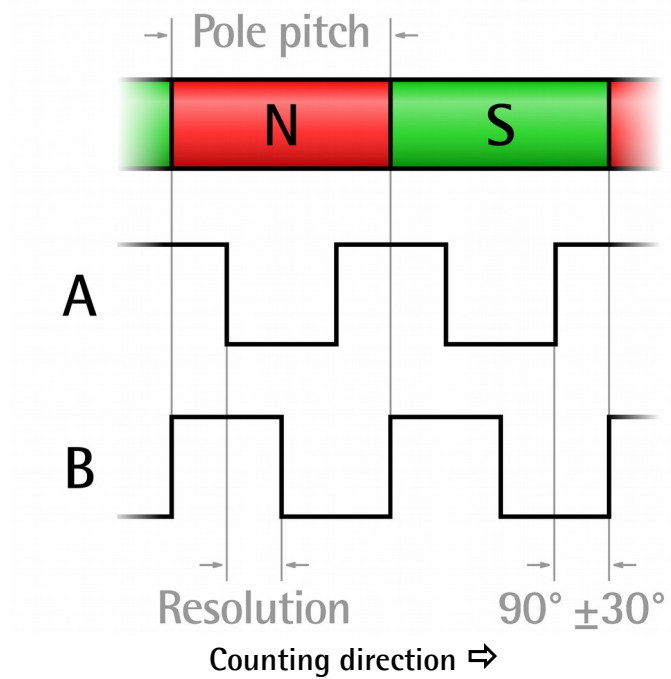

Please note that the incremental signals and their relationship with the pole pitch are represented schematically in the Figure above; in the example the interpolation factor 4x is used. The real interpolation factor results from the size (expressed in μm) of the pole pitch divided by the resolution of the specific sensor.



EXAMPLE

Let's suppose we have a SMA2-G11-50-... sensor
 Resolution = 50 μm
 Pole pitch size in μm = 2000 μm (for all SMA2 devices)

$$\text{Interpolation factor} = \frac{2000}{50} = 40$$

Thus in the case of the SMA2-G11-50-... sensor, the system will provide 40 AB pulses per each pole.



NOTE

Please note that the **Counting direction** parameter available in the BiSS-C interface (see on page 27) affects the absolute position information, not the AB incremental signals.

7.1 Recommended input circuit

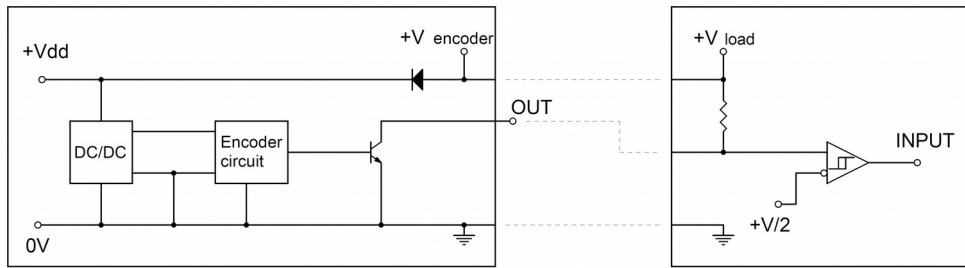

+V encoder = +5Vdc \pm 5%
 +V load = +5Vdc \pm 5% typically
 I_{out} = 40 mA max.

Max. cable length = 10 m, 33 ft
 The max. frequency allowed for the AB signals depends on the cable length and the applied load.

Thermal and short-circuit protections are not provided.

8 - Error and fault diagnostics

In case of wrong alignment between the sensor and the magnetic scale, at power on or during operation the following errors may occur:

- when switching on the system an alarm is triggered through the dedicated bit: the scale is not read correctly; it may be due to one of the following reasons: the scale is not mounted properly (for instance: the scale is mounted contrariwise to the sensor; or it is mounted upside down; see the "3 - Mounting instructions" section on page 10); the scale magnetic surface is damaged somewhere; the sensor is not working properly; this may cause invalid data to be transmitted; as soon as the sensor is aligned correctly the error bit switches to high logic level;
- during operation an alarm is triggered through the dedicated bit: as previously stated, the scale is not read correctly; it may be due to one of the following reasons: the scale is not mounted properly (for instance: the scale is mounted contrariwise to the sensor; or it is mounted upside down; see the "3 - Mounting instructions" section on page 10); the scale magnetic surface is damaged somewhere; the sensor is not working properly; furthermore, the alarm may be caused by a frequency error: the sensor is travelling too fast on the scale. The last valid position is "frozen" (kept in memory) until the next valid position is detected on the scale.

In the SSI interface, the device status is transmitted via the error bit, see the "5.4 Error bit" section on page 18.

In the BiSS interface, the device status is transmitted via the **nE** bit, see the **Error** bit on page 21.



NOTE

When the error bit has high logic level (normal status, no alarm active), this means that the sensor is working properly and both the absolute position information and the incremental signals are output correctly. Please note that the error bit is intended to communicate the status of both the absolute interface and the AB incremental signals.

For further information refer also to the "10 - Troubleshooting" section on page 37.

9 - Maintenance

The magnetic measurement system does not need any particular maintenance; anyway it has to be handled with the utmost care as any delicate electronic equipment. From time to time we recommend the following operations:

- periodically check the soundness of the structure and make sure that there are no loose screws; tighten them if necessary;
- check the mounting tolerances between the sensor and the magnetic scale are met all along the whole measuring length. Mechanical plays compromise the correct operation. Wear of the machine may increase the tolerances;
- the surface of the magnetic scale has to be regularly cleaned using a soft and clean cloth to remove dust, chips, moisture etc.

10 - Troubleshooting

The following list shows some typical faults that may occur during installation and operation of the magnetic measurement system.

Fault

The system does not work (no pulse output).

Possible cause

- The scale and/or the sensor are not installed properly. The active surface of the scale does not match the sensitive part of the sensor; or the sensor installation does not comply with the mounting direction. For correct installation please refer to the "3 - Mounting instructions" section on page 10.
- A magnetic part or a protection surface is interposed between the sensor and the scale. Only non-magnetic materials are allowed between the sensor and the scale.
- Installation does not meet the mounting tolerances between the sensor and the scale indicated in this guide. During operation the sensor hit the surface of the scale (check whether the sensor sensitive part is damaged). Or the sensor is mounted too far from the scale.
- The sensor has been damaged by short circuit or wrong connection.

Fault

The measured values are either inaccurate or not provided in the whole length.

Possible cause

- The mounting tolerances between the sensor and the scale are not met all along the whole measuring length. For correct installation see the "3 - Mounting instructions" section.
- The sensor is not installed properly on the scale (see the "3 - Mounting instructions" section).
- The connection cable runs near high voltage cables or the shield is not connected properly.
- Frequency error: the sensor is travelling too fast on the scale.
- The frequency of the Master clock is set too high or too low and the transmission cannot be synchronized correctly (see the "5 - SSI interface" and "6 - BiSS C-mode interface" sections).
- A section of the magnetic scale has been damaged mechanically or magnetically along the measuring length.
- The measuring error is caused by a torsion in the machine structure. Check parallelism and symmetry in the movement of the machine.

For further information refer also to the "8 - Error and fault diagnostics" section on page 35.

11 - Default parameters list

BiSS-C interface

Parameters list	Default value *		
Command	00		
Configuration	20		
Bit 0 not used	0		
Bit 1 Set preset / offset	0 = Preset		
Bit 2 Enable preset / offset	0 = Enable		
Bit 3 not used	0		
Bit 4 not used	0		
Bit 5 Output code	1 = Binary		
Bit 6 Counting direction	0 = Standard		
Bit 7 not used	0		
Preset / Offset	00 00 00		

* All values are expressed in hexadecimal notation.

This page intentionally left blank

Document release	Release date	Description	HW	SW	Interface
1.0	22.09.2014	First issue			
1.1	21.04.2016	General review, new BiSS order codes			



Dispose separately

lika

Lika Electronic

Via S. Lorenzo, 25 • 36010 Carrè (VI) • Italy

Tel. +39 0445 806600

Fax +39 0445 806699



info@lika.biz • www.lika.biz